

NEXTGEN

INSTALL-TOOLS: CLAMP-SLS MOUNTING BRACKET

- This mounting bracket can be used to mount the NEXTGEN lightline system.
- With this bracket the lightline can be suspended using a steel cable, hook or chain.
- This bracket is ideal for refrigerated areas and food processing companies.



DC

DD

XC

XD

Features

artikel nr.: LUM-NG-60-CLAMP-SLS-01

Dimensions (LxWxH)	65 mm x 2,5 mm x 135 mm
Inner diameter	ø60 mm
Diameter mounting hole	6 mm (±0,5)
Weight	12 g
Material	Stainless steel AISI 316
Temperature range	-40 °C - +400 °C

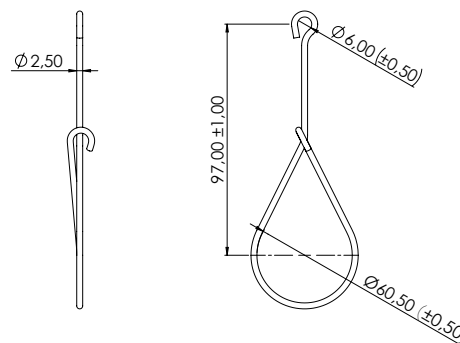

Mounting examples

